

V 39





V39

The V39's ultra-responsive handling and thrilling acceleration is something to behold, especially when the sunroof is open, creating over 5 square metres of open space, it's a true open boating experience. When entertaining, the spacious and sociable cockpit enjoys a beautiful teak table and well-equipped wetbar. And with the option of a sunpad you'll be spoilt for choice.

Le V39 est remarquable pour sa maniabilité ultra réactive et son accélération saisissante, spécialement quand le toit est ouvert, dégageant un espace de 5,2 m² pour d'authentiques sensations de navigation. Parfait pour recevoir, le cockpit spacieux est équipé d'une superbe table en teck et d'un bar accueillant avec barbecue intégré, évier et réfrigérateur bas. Et avec l'option d'un bain de soleil arrière, vous avez l'embarras du choix.

Die extrem reaktionsstarke Handhabung der V39 und ihre mitreißende Beschleunigung sind etwas, dass Sie gesehen haben müssen; vor allem bei zurückgeklapptem Schiebedach, wodurch eine 5,2 m² große offene Fläche entsteht, ist das Bootfahren eine Erfahrung, die Sie unbedingt mitmachen müssen. Das geräumige Cockpit bietet für unterhaltsame Momente einen wunderschönen Teakholztisch und eine gesellige Bar mit eingebautem BBQ, Spülbecken und Minikühlschrank. Mit der optionalen Schiebedachversion werden Sie vollkommen verwöhnt.

La manovrabilità ultra-reattiva e l'emozionante accelerazione del V39 sono aspetti da sperimentare in prima persona, soprattutto quando il tettuccio è aperto creando così 5,2 m² di spazio aperto per un'esperienza nautica autentica. Per l'intrattenimento, l'ampio pozzetto è provvisto di un bellissimo tavolo in teak ed un mobile bar per socializzare con barbecue da incasso, lavello e frigo a pozzetto. E con il modello il 2015 potete eventualmente optare per la versione con prendisole. Come vedete, c'è l'imbarazzo della scelta...

Отличительные черты этой яхты — невероятно чёткое управление и захватывающая дух скорость. Этим стоит насладиться, особенно с открытой крышей: благодаря этому Вы получаете более 5 квадратных метров открытого пространства в салоне. Незабываемое ощущение! Для полноценного отдыха в кокпите есть всё необходимое: красивый стол из тикового дерева, удобный бар со встроенным барбекю, раковина и холодильник. С новой опцией санпада на кокпите Ваш отдых станет незабываемым.





Below deck, the well proportioned galley enjoys plentiful natural light and intelligent storage. The master cabin has impressive headroom, space and light, whilst the aft cabin can be specified with sliding berths to make a cossetting double. With hand-stitched detailing, handcrafted cabinetry and spacious accommodation, it's a craft built without compromise.

Sous les ponts, la cuisine spacieuse est suffisamment baignée de lumière naturelle et dispose de rangements intelligents. La cabine du propriétaire claire et spacieuse a une incroyable hauteur sous plafond, et les couchettes des cabines intermédiaires peuvent facilement être rapprochées pour former un grand lit douillet. Grâce aux détails cousus main, aux meubles de facture artisanale et à la pleine hauteur sous plafond, c'est un bateau conçu sans aucun compromis.

Auf den Unterdecks bietet die geräumige Kombüse viel natürlichen Lichteinfall und intelligente Aufbewahrungsmöglichkeiten. Die Master-Kabine besitzt unglaubliche Kopffreiheit und ist geräumig und leicht, während die Kojen der Mittelkabinen auf einfache Weise zu einem gemütlichen Doppelbett zusammengeschoben werden können. Mit seinen handgestickten Details, den handgefertigten Möbeln und den hohen Toilettenräumen ist die V39 ein Boot, das ohne Kompromisse gebaut worden ist.



Sottocoperta, la spaziosa cucina è inondata di luce naturale e offre uno spazio di conservazione intelligente. La cabina armatoriale ha un'altezza incredibile, oltre che essere molto spaziosa e luminosa, mentre i letti delle cabine centrali scorrono facilmente insieme trasformandosi in un accogliente letto matrimoniale. I dettagli cuciti a mano, i mobili realizzati artigianalmente e i bagni ad altezza intera lo rendono uno yacht che non scende a compromessi.

Ниже на палубе расположена кухня с естественным освещением и предусмотрено много места для хранения. Мастер-каюта приятно удивляет высотой потолка, объёмом и освещённостью, а кровати гостевой каюты легко сдвигаются, образуя полноценную двухспальную кровать. Что ещё? Мебель и детали интерьера, выполненные вручную — эта яхта обладает неповторимым очарованием и уже получила признание во всем мире.



MAIN DECK

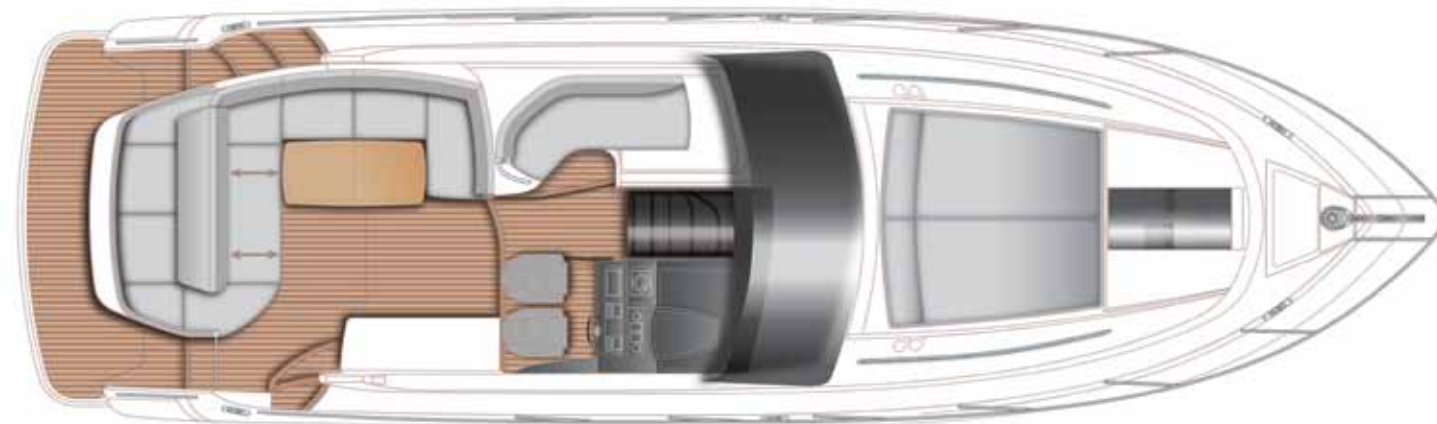

MAIN DECK WITH SUNPAD OPTION



LOWER DECK

PRINCIPAL DIMENSIONS

Length overall (incl. pulpit)	42ft 6in (12.98m)
Length overall (excl. pulpit)	41ft 6in (12.65m)
Length of hull (excluding swimming platform)	39ft 3in (11.99m)
Beam	12ft 5in (3.81m)
Draft: (Drives raised)	1ft 10in (0.56m)
Draft: (Drives lowered)	3ft 4in (1.02m)
Displacement approx.	9,900kg (21,825 lbs)*
Fuel capacity	160 gal/192 US gal/730l
Water capacity (incl. calorifier)	73 gal/88 US gal/332l

ENGINE OPTIONS - DIESEL

Twin Volvo D6-330 DP (2 x 330mhp)	Speed range: 37-39 knots†
-----------------------------------	---------------------------

DECK FITTINGS

- Teak-laid transom platform, cockpit deck and stairs to side decks
- Reversible electric anchor winch with helm position controls
- Self-stowing 16kg/35lbs Delta anchor with 30m of chain
- Stainless steel cleats, fairleads and handrails
- Remote control searchlight
- Chain locker with stowage for 4 fenders (stowage for an additional 2 fenders in engine room)

COCKPIT

- U-shaped seating with teak table (with optional conversion to double sunbed)
- L-shaped seat
- Electrically operated sliding sun roof
- Wetbar including sink, drawer refrigerator and optional electric barbecue
- Lockable gas strut assisted hatch to engine room
- Transom gate leading to bathing platform (with optional electro-hydraulic raise/lower mechanism), foldaway swimming ladder and hot and cold shower
- Lifteraft storage locker
- Large transom storage locker
- Locker housing 240v shore support inlet
- Locker with remote fuel cocks
- Cockpit cover
- Optional sunpad layout available with aft seat extension and sliding backrests for conversion

HELM POSITION

- Twin helm seat with bolster
- Full engine instrumentation including fuel gauges and engine controls
- Navigation system including VHF/RT, speed and distance log, echo sounder with alarm and high speed magnetic compass
- Controls for windscreen wipers, bilge pump, anchor winch, trim tabs and sterndrive trim
- Chart table
- Remote control searchlight

SALOON

- U-shaped sofa with dining table (converts to double berth)
- Sideboard unit with glass and bottle storage
- Stereo radio/MP3 with saloon and cockpit speakers
- 24v and 220/240v electrical control panels
- Storage lockers

GALLEY

- 3-zone gas hob with flame-failure device
- Remote solenoid switch for gas system
- Combination microwave/conventional oven with grill
- Stainless steel sink with monobloc mixer tap
- Refrigerator with freezer compartment
- Waste bin
- Storage cupboards, drawers and lockers

ACCOMMODATION & INTERIOR FINISHES

- All cabins and bathroom feature opening portholes
- All cabins feature 220/240v power points
- All mattresses pocket sprung
- Furniture in Rovere Oak with satin or high gloss finish. American Walnut or Alba Oak available as an option
- Avonite worktops and tiled floors in all guest bathrooms
- Avonite worktop and timber-laid floor in galley
- Choice of high quality carpet and upholstery fabric from extensive range
- Curtains, blinds or sunscreens to all windows and portholes

OWNER'S CABIN

- Large double bed with drawers below
- Wardrobe with shelves
- Vanity unit
- Storage lockers and drawers
- Deck hatch with integrated skylight and blind
- Overhead and individual berth lights
- En suite bathroom with day access incorporating electric freshwater toilet, separate stall shower, 240v shaver point, storage lockers and mirror

AFT GUEST CABIN

- Two single beds with storage below (with option of sliding conversion to double)
- Sofa (with option of conversion to berth) with hydraulic back-up
- Storage lockers and drawers
- Overhead and individual berth lights

POWER AND DRIVE SYSTEMS

- Twin duo-prop stern drives
- Power-assisted electronic steering system with hydraulic back-up
- Electronic engine and gear shift controls
- Engine room extractor fan

ELECTRICAL SYSTEMS

- 12 Volt:
 - 2 x heavy-duty batteries for engine starting
 - 2 x heavy-duty auxiliary batteries
 - Battery link facility with remote control at helm position
 - 70 amp battery charger charging both banks of batteries via automatic switch charging system
 - LED lighting throughout

220 Volt:

- Shore support inlet in cockpit locker with storage for cable
- Polarity check system
- Earth leakage safety trip
- Power points to all areas

FUEL SYSTEM

- Twin fuel tanks (in NS8 marine grade alloy) with interconnection system giving 143 gal/172 US gal/650l capacity
- Fuel fillers on port and starboard side decks
- High-capacity fuel filters/water traps
- Deck filler

WATER SYSTEM

- 73 gal/88 US gal/332l plus 7 gal/8.5 US gal/36l hot water calorifier and heated by engine and 240v immersion heater
- Water level gauge
- Deck filler

FIRE EXTINGUISHERS

- Automatic/manual override fire extinguisher in engine room with warning system at helm position
- Hand-operated fire extinguishers (4) in owner's cabin, guest cabin, galley and cockpit

BILGE PUMPS

- Automatic electric bilge pumps (2)
- High-capacity manual bilge pump with valve system and suction points in same areas

OTHER ITEMS SUPPLIED AS STANDARD

- Ensign staff
- Fenders (6) and warps (4)
- First Aid kit
- Tool kit
- Set of manuals
- Quilted bedspreads in all cabins